

RSR-72

AUTO RESTART MOTORS RELAY

The RSR-72 type relay for re-start and reacceleration is designed to perform the automatic motor restarting, after control and protection device opening, as a consequence of a momentary line voltage interruption or drop-out.

The RSR-72 relays allow, after the stop of the motors, the automatic re-start with a correct sequence depending of the working process.

The RSR-72 relays are housed in a case for flush mounting or panel mounting or on DIN rail 35 mm on extractible undecal socket type. On front panel there are potentiometers and micro-switches for settings and one LED to indicate the functional status.



ORDER CODE	RATED AUXILIARY SUPPLY VOLTAGE
RSR-72	For applications with the control device of the contactor with contact impulsive position.
RSR-72A	For applications with device contactor control with a maintained contact.
RSR-A72B	For applications with the control device of the contactor with contact impulsive position with special mode of the memory count.
OPTIONS	
F	Tropicalisation
Z	Undecal support
M	Restraint spring for fixing undecal support

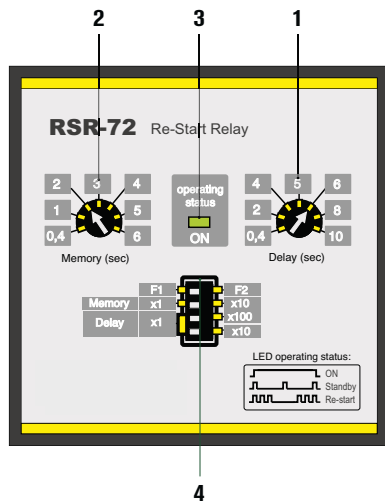

GENERAL CHARACTERISTICS

The RSR-72 relay is used in association with an holding position contact.

Otherwise from the RSR-72, **the RSR-72A maintains the contact closed after the restarting the motor/contactor.**

On the relay is possible to set a memory time from 0.2 to 60 seconds and a delay time from 0.2 to 1000 seconds.

Anytime a voltage lack (or with a value less of 65% of the rated voltage) and subsequently the voltage restores (at least the 90% of the rated voltage) within the memory time set the re-start motor output will be activated after the delay set.

If the voltage restores after the memory time, the automatic re-start will not happen, while the voltage restores in a time less than 0.2 seconds (the minimum memory time), the motor will reaccelerate.

If the reacceleration function is activated and the voltage go back in a time less than 0.2 seconds (maximum time for reacceleration) the motor will reaccelerate immediately, if the reacceleration function is not activated after the delay time the motor will restart automatically.

- SUPPLY CIRCUIT AND VOLTAGE CONTROL
- CIRCUIT OF CONTACTOR CONTROL AND OF MEMORY ACTIVATION WITH SEPARATION BY PHOTO-COUPLER
- CIRCUIT OF MOTOR STOP CONTROL BY PA PUSHBUTTON (STOP) AND QUICK MEMORY SHUTDOWN SEPARATED BY PHOTO-COUPLER.
- CIRCUIT FOR FINAL RELAY CLOSING AND CONTROL CIRCUIT ARE MANAGED BY MICROPROCESSOR

LEGENDA	
1	Tripping delay time adjustment
2	Regolazione tempo di memoria
3	<p>LED OPERATING STATUS.</p> <p>OFF = power supply and measure voltage are not present ON = relay in normal voltage measurement within the expected range SLOW = relay in stand-by, the voltage lack for a time greater than the time memory, the restart is not executed even if the supply voltage is present. FAST = relay in restart, the voltage lack has been for a time less than memory time, after the delay time set the re-start will be done</p>
4	<p>DIP SWITCHES SETTINGS:</p> <p>4a - F1 - F2 reacceleration function F1 = acceleration deactivated F2 = acceleration activated</p> <p>4b - x1 - x10 constant selection for memory time adjustment. Examples: positioning the dip switch on x10 and the potentiometer on 3 we will have a memory time of $3 \times 10 = 30$ seconds; positioning the dip switch on x1 and the potentiometer on 3 we will have a memory time of $3 \times 1 = 3$ seconds</p> <p>4c - x1 - x10 - x1000 constant selection for tripping delay time adjustment. The constants in relation to the position of the 2 dip switches are the following:</p> <ul style="list-style-type: none"> • dip switch position x1 and x1 K = 1 • dip switch position x1 and x10 K = 10 • dip switch position x1 and x100 K = 100

RSR-72

AUTO RESTART MOTORS RELAY

TECHNICAL CHARACTERISTICS	RSR-72	RSR-72A	RSR-72B
CONTROL CIRCUIT			
Control voltage	240 VAC o 110 VAC o 110 VDC		
Adjustments time (t)	da 0,2 a 1000 s		
Adjustments tripping set-point (IΔ)	da 0,2 a 60 s		
Threshold voltage lack	70% of rated voltage		
Threshold voltage restore	90% of rated voltage		
Minimum time for detecting the voltage lack	10 ms		
Maximum reacceleration time	max 0,2s		
Pulse duration to restart	0,7 s		
AUXILIARY SUPPLY			
Auxiliary voltage (Us)	240 VAC o 110 VAC o 110 VDC		
Rated frequency	50-60 Hz		
Maximum power consumption	3 VA		
OUTPUT RELAYS			
Contact arrangement	1 relay Normally open		
Rated contact capacity Ith	5 A (240 VAC) – 0,4 A (110 VDC)		
INSULATION			
Insulation test	2,5kV for 1 minute		
AMBIENT OPERATING CONDITIONS			
Operating temperature	-10+60 °C		
Storage temperature	-20+80 °C		
Relative humidity	≤ 95%		
ENCLOSURE			
Version	Flush mount 72x72mm		
Degree of protection	IP20 terminals IP54 with protective cover		
CERTIFICATIONS AND COMPLIANCE			
Reference standards	CEI 41.1 CEI EN60255-6, EN 50081-2, EN 50082-2		

WIRING CONNECTION RSR-72 / RSR-72B - RSR-72A

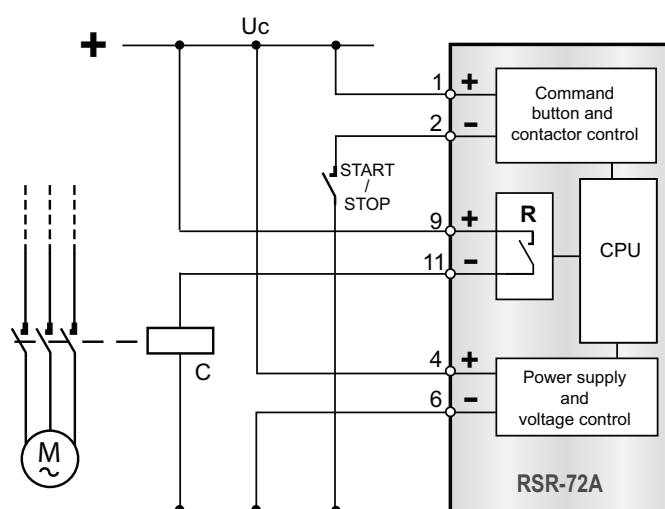
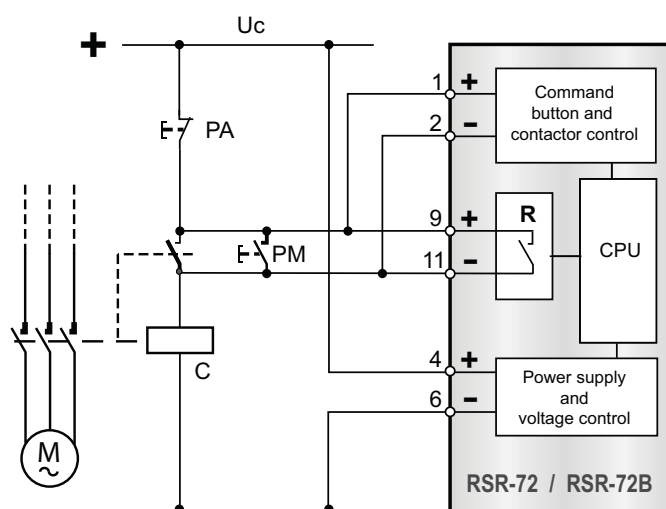

Uc	Power supply line of the contactor and power supply and control voltage
PA	Stop motor button (STOP)
PM	Start motor button (START)

C	Contactor of command motor
M	Motor
R	Output relay for re-start an reaccelerate command

RSR-72

AUTO RESTART MOTORS RELAY

OPERATING

When the voltage is under the threshold of the 65% of the rated voltage, for the RSR-72 relay is a voltage lack.
When the voltage restores over the threshold of the 90% of the rated voltage, for the RSR-72 the voltage is ok.

1. With power supply, the RSR-72 relay is in STAND-BY way and the LED blink with rate 1/1.
In this way if the voltage go under the threshold value, no operation of restart is performed.
2. Pressing the PM button (START)
 - the contactor is energized and self-retained by its auxiliary contact
 - the motor starts , the "R" contact is open
 - the memory circuit inside the RSR-72 relay is activated
 - RSR 72 go in ON position, signalled by the led also fixed in ON position
3. In case of temporary voltage lack:
 - 3a. if voltage is OFF for a time longer of the MEMORY time set:
 - the motor remain out of service and the contactor is de-energized
 - the "R" contact is open
 - the RSR 72 go in STANDBY mode, and the led blink at rate 1/1
 - 3b. If voltage is OFF for a time in the range from 0.2 seconds and the MEMORY time fixed:
 - the contactor is de-energized, the RSR-72 relay is in RE-START mode and the LED blink with rate 1/3 beginning the count of the DELAY time set
 - elapsed the delay time, the "R" contact switch in closed giving the pulse to restart, in this way the contactor is energized and the motor restart
 - next the RSR 72 go in ON mode, signalled by the led fixed to ON
 - Version RSR-72B: start to count the MEMORY time when the first power lack happen from condition as in point 2) (motor is running).
More cycles of power lack and power restore can happen during MEMORY time count, with consequently starting of DELAY time before activate R contact);
if before the R contact can re-close another power lack happen, anyway the MEMORY time continue to allow another retry to restart the motor if power will restore;
but if the MEMORY count is all elapsed and restart is not happened, the RSR-72B go in condition as in point 3a)
 - 3c. if the voltage is OFF for a time smaller of 0.2 sec. with reaccelerate function not activated (F1)
 - the functioning is the same of the b) item
 - 3d. if the voltage is OFF for a time smaller of 0.2 sec. with reaccelerate function activated (F2)
 - the contactor is de-energized, when the voltage restores the RSR-72 relay active immediately the reaccelerate of the motor, the "R" contact switch in closed giving the pulse to reaccelerate.
4. Pressing the "PA" push-button (STOP)
 - 4a. he contactor-switch is de-energized, the motor stops
 - 4b. the memory circuit inside the RSR-72 relay is deactivated
 - 4c. the "R" contact is open and the motor automatic restart does not occur
 - 4d. the RSR-72 go in STANDBY mode, and the LED blink at rate 1/1
5. After operation of item 4 in case of lack and recovery of the supply voltage, the motor automatic restart doesn't occur
6. In case of pushing of the "PA" push-button (STOP) during the count of re-start time (operation of item 3b)
 - the memory is deactivated;
 - the "R" contact does not close and the motor automatic restart does not occur
 - the RSR 72 go in STANDBY mode, and the led blink at rate 1/1.
7. Each "NC" contact placed directly in series to "PA" pushbutton carries out the same function of "PA" push-button
8. Each "NO" contact placed directly in parallel to "PM" pushbutton carries out the same function of "PM" push-button.

MECHANICAL DIMENSIONS

